

BIOSAFE sequential mechanical basin mixer

Ref. 2664T2

Tall single hole sequential mixer H. 160mm L. 250mm

DESCRIPTION

BIOSAFE sequential mechanical basin mixer - Ref. 2664T2

Deck-mounted tall mechanical basin mixer.
Sequential mechanical mixer: opens and closes with cold water over a range of 70°.

Single hole mixer with swivelling spout H. 160mm L. 250mm.

Tall mixer with BIOSAFE hygienic outlet suitable for fitting a BIOFIL terminal filter.

Ø 35 sequential ceramic cartridge with pre-set maximum temperature limiter.
Spout with internal tube with smooth interior, with nowhere for bacteria to develop and very low water volume.

The speed of the water inside this tube reduces biofilm development considerably.

Thermal shocks are possible without removing the control lever or shutting off the cold water supply.

Body with very low water volume (fewer niches where bacteria can develop).

Flow rate regulated at 5 lpm.

Hygiene control lever L. 150mm requires no manual contact.

Rotating PEX flexibles F3/8".

No risk of cross flow between the hot and cold water.

No non-return valves on the inlets.

Fixings reinforced by 2 stainless steel rods.

Mixer ideal for healthcare facilities, retirement and care homes, hospitals and clinics.

Mixer suitable for people with reduced mobility.

30-year warranty.

TECHNICAL CHARACTERISTICS

BIOSAFE sequential mechanical basin mixer - Ref. 2664T2

Supply	3/8"
Technology	Sequential mechanical mixer
Drop height	160mm
Spout length	250mm
Flow rate	5 lpm
Temperature limiter	Yes
Finish	Chrome-plated brass
Norms	ACS



ADVANTAGES



Sequential: opens/closes with cold water



Thermal shock without removing the control lever



Maximum hygiene: controls biofilm



No manual contact: Hygiene control lever

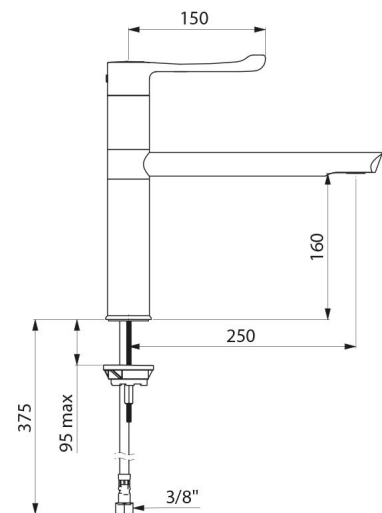

Warranty

